

XR 300 LS

Part No.: 8300003

- Load Sense

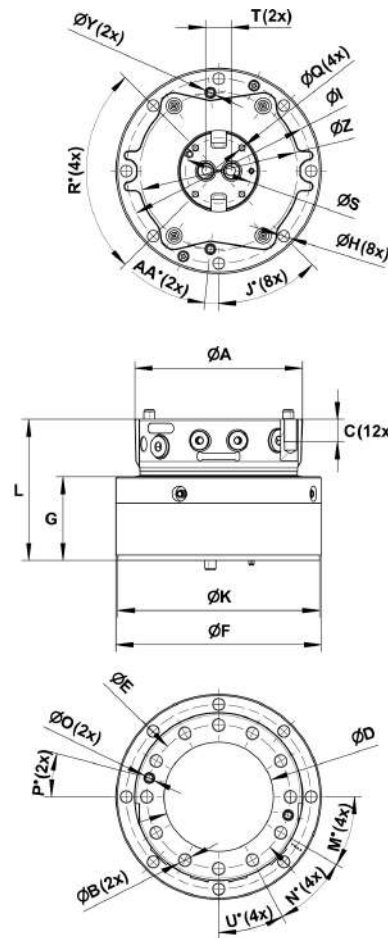

Upper	
G GO:	R:
G 3/4	G 1/2

A: Ø244,7 mm	AA: 6°	B: M20	C: 33 mm	D: Ø160 mm	E: Ø210 mm	F: Ø300 mm	G: 122,3 mm	H: Ø17 mm	I: Ø270 mm	J: 45°	K: Ø295 mm	L: 206,3 mm	M: 30°
N: 32°	O: Ø16 mm	P: 15°	Q: M10	R: 90°	S: Ø96 mm	T: 19 mm	U: 28°	Y: Ø16 mm	Z: Ø230 mm				

77 kg	360°	Max ±300 kN	Max ±90 kN	Max ±70 kN	3000 Nm	Max 28 RPM	Max 28 l/min	Max 25 MPa	Max 35 MPa	Max 35 MPa

A rotator with the shortening LS is not equipped with restrictors (unlike our standard rotators). This means that the oil flow from the base machine has to be adapted.

Max axial load static indicate theoretical max load for hanging applications without accelerations.

Oil distributor ordered separately.

Can be supplemented with hose guard.

We reserve the right to make product changes. For further technical information relating to integration and hydraulic connections, please contact rotator@indexator.com